



MCC Mill

Vol. 01



6 flutes,
Ø5mm

60° & 90° Deburring, 55° & 60° Threading

▶ **Optimum 6 flutes design, the smallest insert dia. is 5mm.**

- Min. deburring bore from Ø4.2mm.
- The smallest insert Ø5.0 can do M6xP0.75 internal threading and deburring.

▶ **Specialized on narrow space below 10mm by indexable inserts.**

▶ **Various MCC inserts can fit on the same holder.**



▶ **Excellent threading surface finishing.**

▶ **Patented Nine9 clamping system to provide high precision and accurate position. Fully ground insert geometry for burr free.**

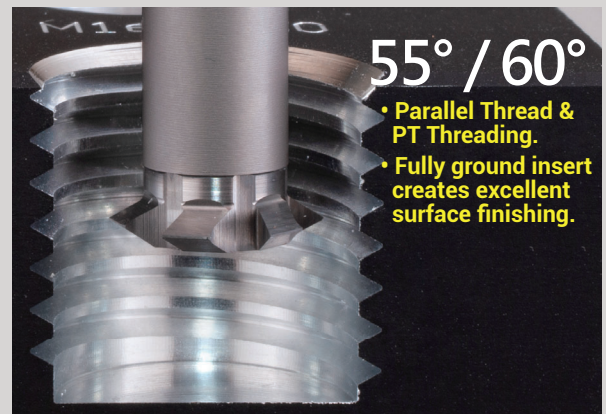
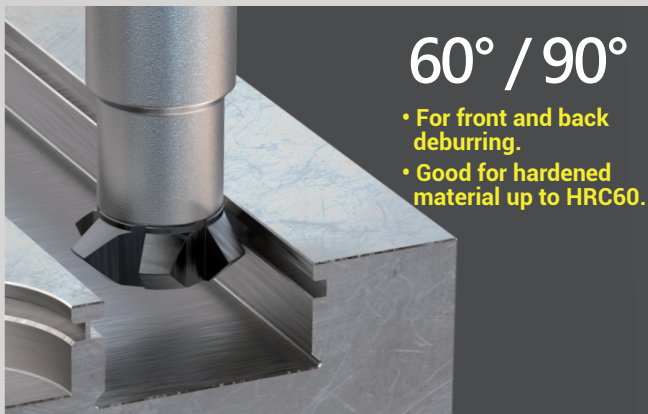



Multiple flutes

Nine9[®]

Deburring & Chamfering

Ultra high speed & feed rate
Excellent positioning accuracy



Visit website for more information

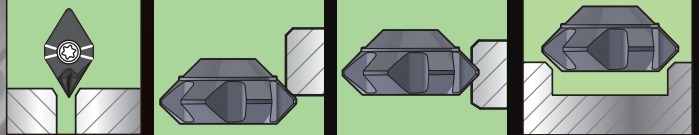

Wide range, no limited for your variety needs

With a suite of Nine9 Deburring and chamfering tools to match every scenario and material, no matter front and back deburring or contour chamfering, all can be finished to exacting standards in a fast and simple manner – upgrading your machining process without manpower shortage, negating precision and accuracy.

Ø0.5

Ø32



NC
Deburring
60° / 90°
Insert has
6 flutes

MCC Mill
Deburring 60° / 90° &
Threading 55° / 60°
Insert has 6 flutes

Front and back Chamfer Mill 45°
4-tooth type

NC Deburring 60° / 90°



Smallest deburring dia.
from Ø0.5mm.

- Ideal for fine hole deburring.
- Insert has 6 flutes, 6 times higher feed rate.
- Achieve high speed and feed rate on CNC machine.

MCC Deburring 60° / 90°



Smallest deburring dia.
from Ø4.2mm.

- Front and back deburring, 60° also for threading
- Insert has 6 flutes, 6 times higher feed rate.

Chamfer Mill 45°



Smallest chamfer dia.
from Ø7mm.

- Front and back chamfering.
- 4-tooth, 4 times faster and up to 10 times higher feed rate than competitors.

MCC Mill- Deburring

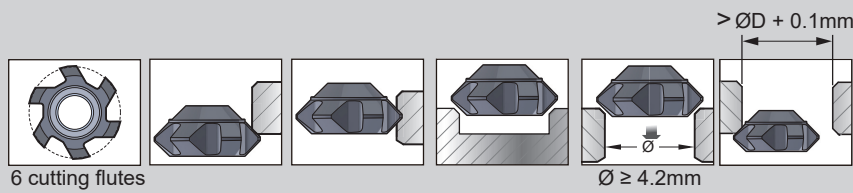

► Inserts >>

- NC2032:** • TiAlN coating provides longer tool life.
 - For all kinds of steel < 60 HRC, carbon steel, alloy steel and cast iron.
- XP9000:** • High positive and sharp edge produces excellent surface finish.
 - For non-ferrous material such as aluminum, brass, copper and soft material.

► 60° deburring

- For front and back deburring.
- Also for threading application.

Holder Size	Code	Parts No.	Coating	Grade		$\varnothing D$ ± 0.025	L1	L2	S ± 0.025	C	0.1C	
											min. hole	max. hole
CR05	01R2103	R06005-05010-32	TiAlN	K20F		5.0	0.35	0.45	2.0	0.40	4.2	4.8
	01R2104	R06005-05010-00	Uncoated									
CR07	01R2301	R06007-06810-32	TiAlN	K20F		6.8	0.40	0.50	2.35	0.50	5.6	6.6
	01R2302	R06007-06810-00	Uncoated									
CR10	01R2601	R06010-08510-32	TiAlN	K20F		8.5	0.49	0.59	3.60	0.65	7.2	8.3
	01R2602	R06010-08510-00	Uncoated									
	01R2603	R06010-10010-32	TiAlN									
	01R2604	R06010-10010-00	Uncoated									

► 90° deburring

- Front and back deburring in one operation.

Holder Size	Code	Parts No.	Coating	Grade		$\varnothing D$ ± 0.025	L1	L2	S ± 0.025	C	0.1C	
											min. hole	max. hole
CR05	01R4101	R09005-05060-32	TiAlN	K20F		5.0	0.60	1.20	2.00	0.4	4.2	4.8
	01R4102	R09005-05060-00	Uncoated									
CR07	01R4301	R09007-07020-32	TiAlN	K20F		7.0	1.00	1.20	2.35	0.7	5.6	6.8
	01R4302	R09007-07020-00	Uncoated									
CR10	01R4601	R09010-10010-32	TiAlN	K20F		10.0	1.45	1.55	3.60	1.2	7.6	9.8
	01R4602	R09010-10010-00	Uncoated									

MCC Mill- Threading

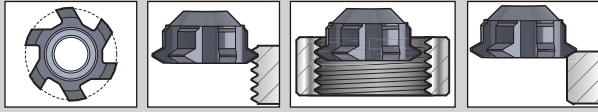

6 cutting flutes

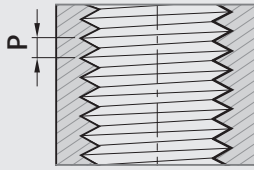

55° Parallel Pipe thread
60° Parallel thread

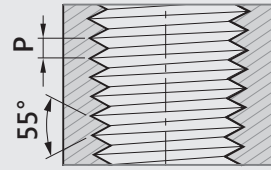

55° Tapered Pipe thread

► Inserts >>

- NC2032:** • TiAlN coating provides longer tool life.
 - For all kinds of steel < 50 HRC, carbon steel, alloy steel and cast iron.
- XP9000:** • High positive and sharp edge produces excellent surface finish.
 - For non-ferrous material such as aluminum, brass, copper and soft material.

► 55° Parallel Pipe Thread: Ideal for milling parallel threads such as JIS-PF, G (BSF, BSP).

Holder Size	Code	Parts No.	Coating	Grade		ØD ±0.025	ØD1	L	S ±0.025	Pitch range	
										TPI	
CR07	01R1301	R05507-06512-32	TiAlN	K20F		6.56	5.32	0.12	2.35	28	
	01R1302	R05507-06512-00	Uncoated								
CR10	01R1601	R05510-10018-32	TiAlN	K20F		10.0	6.92	0.18	3.60	19 - 14	
	01R1602	R05510-10018-00	Uncoated								

► 55° Tapered Pipe Thread: Perfect for milling tapered threads like JIS-PT, BSPT.

- Mill a tapered thread directly into a drilled hole without the need to pre-mill the taper.

Holder Size	Code	Parts No.	Coating	Grade		ØD ±0.025	ØD1	ØD2	L	S ±0.025	Pitch range	
											TPI	
CR10	01R1603	R05510-09516-32	TiAlN	K20F		9.50	6.8	7.68	0.16	3.6	19	
	01R1604	R05510-09516-00	Uncoated									
	01R1605	R05510-10025-32	TiAlN	K20F		10.0	6.8	7.58	0.25	3.6	14	
	01R1606	R05510-10025-00	Uncoated									

► 60° Parallel Thread

Holder Size	Code	Parts No.	Coating	Grade		ØD ±0.025	ØD1	L	S ±0.025	Pitch range	
										mm	TPI
CR05	01R2101	R06005-05006-32	TiAlN	K20F		5.0	3.9	0.06	2.0	0.6 - 0.75 32 - 28	
	01R2102	R06005-05006-00	Uncoated								
	01R2103	R06005-05010-32	TiAlN								
	01R2104	R06005-05010-00	Uncoated								
CR07	01R2301	R06007-06810-32	TiAlN	K20F		6.8	5.5	0.10	2.35	0.8 - 1.25 28 - 20	
	01R2302	R06007-06810-00	Uncoated								
CR10	01R2601	R06010-08510-32	TiAlN	K20F		8.5	6.9	0.10	3.60	1.0 - 1.5 24 - 18	
	01R2602	R06010-08510-00	Uncoated								
	01R2603	R06010-10010-32	TiAlN								
	01R2604	R06010-10010-00	Uncoated								

MCC Mill

► Feature >>

- Patented clamping system for accurate positioning.

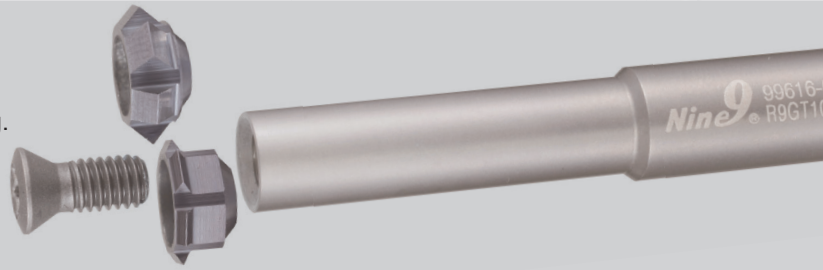

► Holder >>

- Various OAL holders for your choice.
- Carbide shank holders good for fine finish.

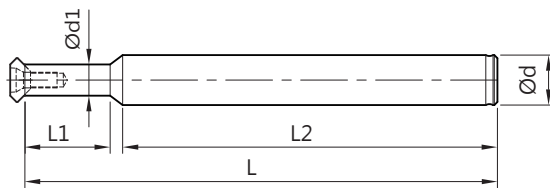

Holder Size	Code	Parts No.	Type	Shank	Ød	Ød1	L1	L2	L	Screw / Key
CR05	70R104	00-99626-CR05-06-039	BC06-CR05-039	Steel	6	3.5	4	33	39	*NS-20045 0.6Nm / NK-T6
	70R105	00-99626-CR05-06-045	BC06-CR05-045		6	3.5	10	33	45	
	70R103	00-99626-CR05-08-076	BC08-CR05-076		8	3.5	10	60	74	
	70R101	00-99626-CR05-05-043	BC05-CR05-043	5	3.5	16	24	41		
	70R106	00-99626-CR05-06-051	BC06-CR05-051	Carbide	6	3.5	16	33	51	
	70R107	00-99626-CR05-06-051W	BC06-CR05-051W		6	3.5	16	33	51	
CR07	70R304	00-99626-CR07-06-041	BC06-CR07-041	Steel	6	5.0	6	33	41	*NS-25060 0.9Nm / NK-T7
	70R303	00-99626-CR07-08-078	BC08-CR07-078		8	5.0	13	60	75	
	70R305	00-99626-CR07-06-049	BC06-CR07-049		6	5.0	14	33	49	
	70R301	00-99626-CR07-06-052	BC06-CR07-052	6	5.0	21	27	49		
	70R306	00-99626-CR07-06-057	BC06-CR07-057	Carbide	6	5.0	22	33	57	
	70R307	00-99626-CR07-06-057W	BC06-CR07-057W		6	5.0	22	33	57	
CR10	70R604	00-99626-CR10-08-049	BC08-CR10-049	Steel	8	6.8	7	40	49	NS-35080 2.5Nm / NK-T15
	70R603	00-99626-CR10-08-082	BC08-CR10-082		8	6.8	16	60	78	
	70R605	00-99626-CR10-08-059	BC08-CR10-059		8	6.8	17	40	59	
	70R606	00-99626-CR10-08-069	BC08-CR10-069		8	6.8	27	40	69	
	70R607	00-99626-CR10-08-084W	BC08-CR10-084W	Carbide	8	6.8	27	55	84	

*Torque screwdriver is recommended.

► Single Set >>

- Included one holder and one insert is available on request.

Example:

Parts No.	Insert included				Holder included		Content
	Type / grade	ØD ±0.025	C	S ±.025	Shank	L	
00-99626-R106-4101	R09005-05060-32	5.0	0.4	2.00	00-99626-CR05-06-051	51	1 tool holder + 1 inserts + 1 key
00-99626-R306-4301	R09007-07020-32	7.0	0.7	2.35	00-99626-CR07-06-057	57	
00-99626-R606-4601	R09010-10010-32	10.0	1.2	3.60	00-99626-CR10-08-069	49	

Cutting Data

► 60° & 90° deburring mill >>

Workpiece material	Vc (m/min)	Feed rate (mm / tooth)	Grade of insert
P Carbon steel	80 ~ 250	0.005 ~ 0.12	NC2032
Alloy steel	60 ~ 200	0.005 ~ 0.10	NC2032
M Stainless steel	40 ~ 120	0.005 ~ 0.10	NC2032
K Cast iron	60 ~ 180	0.005 ~ 0.10	NC2032
N Non-ferrous metal	100 ~ 500	0.005 ~ 0.15	XP9000
H Hardened steel < 60 HRC	30 ~ 80	0.005 ~ 0.05	NC2032

► Performance >>

Work Task: C0.7 back chamfering
 Material: Stainless Steel
 Machine: MECTRON MTS-C420

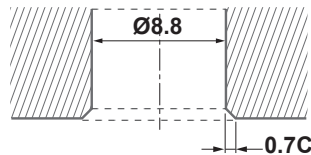

Tool	 	
	MCC Deburring Mill Holder: 00-99626-CR07-049 Insert: R09007-07020-32	Carbide chamfering cutter
Deburring	0.7 mm	0.7 mm
Dia. of cutter mm	7	8
Teeth of cutter	6	3
Spindle Speed r.p.m.	2500	2500
Feed rate mm/min	300	150
RESULT		
Tool life	720 workpiece 	90 workpiece

► Comparison of Surface Quality >>

Material	Deburring	Vc m/min	S r.p.m.	f mm/tooth	F mm/min
SCM415	C0.3	188.5	6000	0.03	1080

Tool: Nine9 MCC Mill
 Holder: 00-99626-CR10-08-082 / Insert: R09010-10010-32

Tool: Other brand chamfering cutter

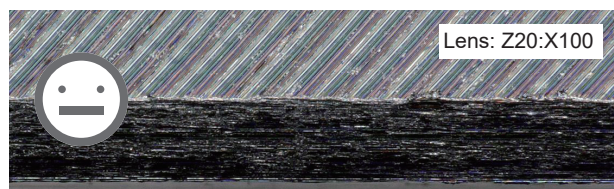
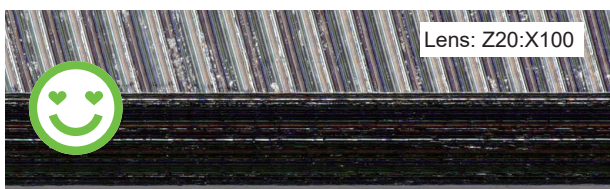

Cutting Data

► 55° & 60° thread milling >>

	Workpiece material	Vc (m/min)	Feed rate (mm / tooth)	Grade of insert
P	Carbon steel	40 ~ 120	0.002 ~ 0.013	NC2032
	Alloy steel	30 ~ 90	0.002 ~ 0.01	NC2032
M	Stainless steel	30 ~ 80	0.002 ~ 0.01	NC2032
K	Cast iron	40 ~ 100	0.002 ~ 0.01	NC2032
N	Non-ferrous metal	60 ~ 200	0.002 ~ 0.013	XP9000
H	Hardened steel < 50 HRC	20 ~ 60	0.002 ~ 0.008	NC2032

► Sample program of internal thread milling

Workpiece: Carbon steel
 Thread: M8xP1.25
 Prebore: ø6.8 depth 12 mm
 Tool holder: 00-99626-CR07-06-049
 Insert: R06007-06810-32

Cutting data:
 Vc= 100 m/min. fz= 0.005mm/tooth
 S= 4680 rpm F= 140.4 mm/min. (feed rate of tool center)

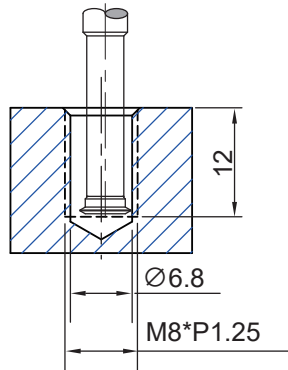

```

%1030
G00G90X0.Y0.
S4680 M03
G43H03Z30. M08
Z5.
G01 Z-12. F200.
G03 X0.65 Y0. R0.8 F46.8
G03 I-0.65 Z0-10.75 F140.4
G03 I-0.65 Z-9.5
G03 I-0.65 Z-8.25
G03 I-0.65 Z-7.
G03 I-0.65 Z-5.75
G03 I-0.65 Z-4.5
G03 I-0.65 Z-3.25
G03 I-0.65 Z-2.
G03 I-0.65 Z-0.75
G03 I-0.65 Z0.5
G00 G90 Z5. M09
G00 G90 Z30. M05
G28 G91 Z0.
M30
%
```

For thread milling on CNC turning machine without Y-axis.

$$F_{tc} = F = S * f_z * z$$

Work spindle speed N:

$$N = \frac{F_{tc}}{2 * \pi * x1}$$

x1 is the depth of thread

Z-axis feed rate= pitch of thread (mm)

Direction of N depends on the left hand or right hand thread.

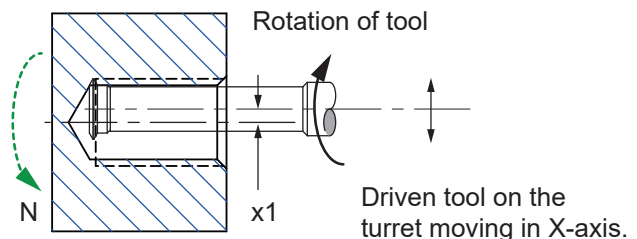

Friendly reminding: Upward and outward thread milling is recommended for all threads, except 55° PT threading.



Nine9[®]

NC Spot Drill

Multi-Functional Tool

SINCE 2001

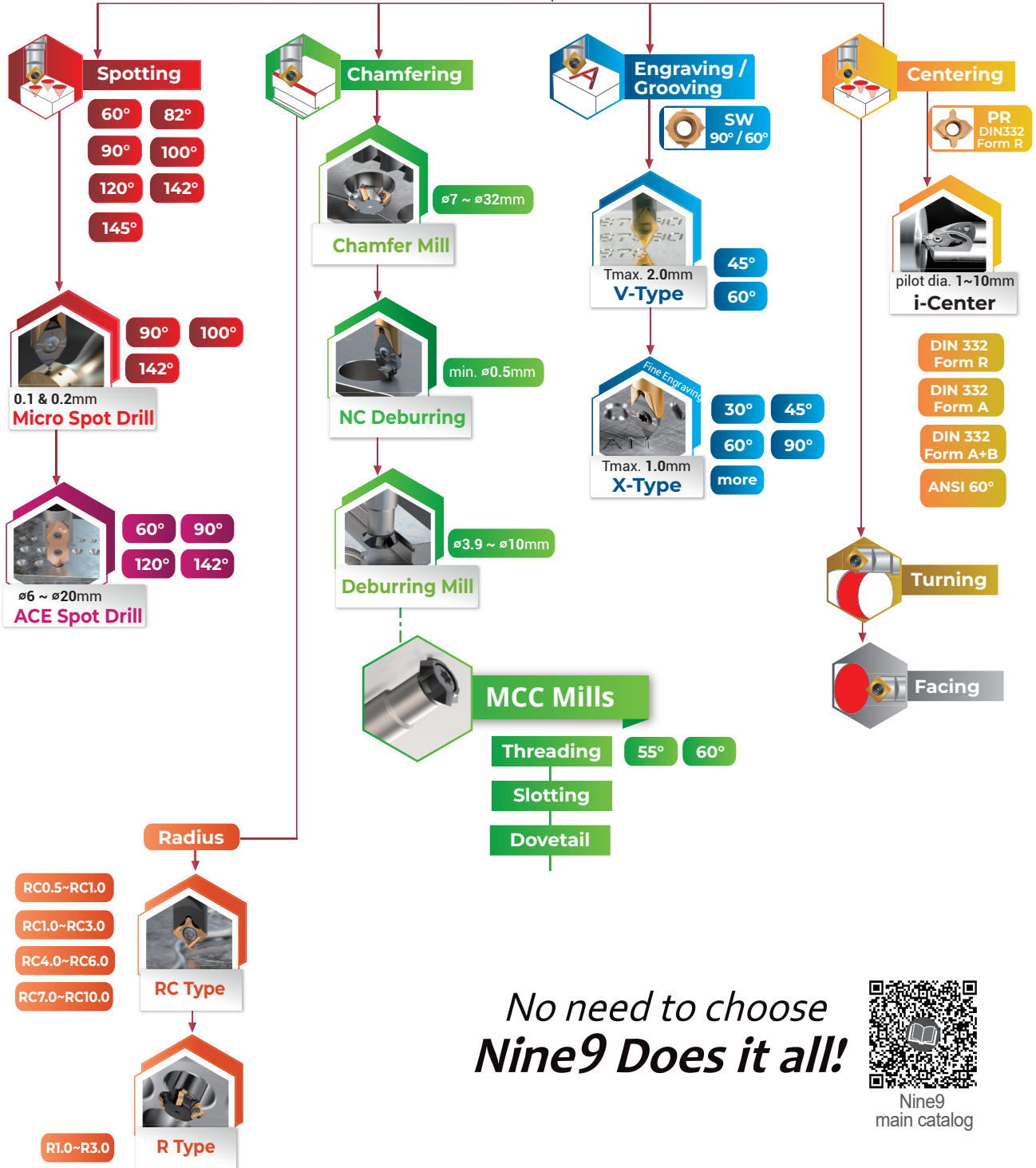

*No need to choose
Nine9 Does it all!*



Nine9
main catalog

